

DT-880
Electronic Audio Detector
User Manual



Contents

1 Overview	1
2 Citation documents	1
3 Technical parameters	2
4 Structural features and how it works	3
4.1 Structure	3
4.2 Components	3
4.3 Dimensions	4
4.4 How it works	4
5 Installation and Commissioning	5
6 How to Use	5
6.1 Buttons and menus	5
6.1.1 Buttons	5
6.1.2 Menus	6
6.2 Boot up the detector	7
6.3 Functional check	7
6.4 How to detect	8
6.5 Turn off the detector	8
6.6 Charging	9
7 Maintenance	10
7.1 Maintenance of service life	10
7.2 Daily maintenance	10
8 Troubleshooting	10
9 Precautions	11
10 Transport, storage	11
10.1 Transport	11
10.2 Storage	11
11 Packing list	12

DT-880

Electronic Audio Detector User Manual

1 Overview

The DT-880 Electronic Audio Detector can be used to detect electronic pointer timed detonators and mechanical timed detonators concealed under various packaging covers. Electronic detonators include timed detonators made from electronic watches, pagers and various remote control devices. Electronic Audio Detector can also be used as counter-surveillance security technology to detect electronic eavesdropping devices and covert video recording devices.

The product consists of the following components.

- a) Electronic Audio Detector mainframe: for detection
- b) Headphones: for outputting audio information
- c) Power adapter: for charging the mainframe
- d) Electronic specimen: for testing the detection function of the mainframe
- e) Mechanical specimen: for testing the detection function of the mainframe
- f) Cables: for the connection of the mainframe to the power adapter and headphones (two cables)
- g) Transit case: for the storage and transport of all components

2 Citation documents

None

3 Technical parameters

See Table 1 for the technical parameters of the equipment

Table 1 Technical parameters

Items	Index
Detection distance	Φ35 mechanical watch: ≥ 430cm
	Electronic hand clock: ≥80cm
	Electronic digital clock: ≥80cm
Penetration distance	Φ35 mechanical watch: 200mm thick polyethylene foam + 200mm thick 70g A4 printing paper
	Electronic hand clock: 200mm polyethylene foam + 150mm 70g A4 printing paper
	Electronic digital clock: 100mm thick polyethylene foam + 50mm thick 70g A4 printing paper
Display method	LCD screen display
Waveform scan rate	4-speed adjustable
Battery type	li-ion battery
Battery operating time	≥6H
Operating temperature	-30°C ~ 55°C
Storage temperature	-40°C ~ 70°C
Relative humidity	≤95%, no condensate
Weight	1.00kg
Dimensions	209mm * 132mm * 154mm
Transit case	410mm*290mm*268mm

4 Structural features and how it works

4.1 Structure

The appearance of the detector mainframe is shown in Figure 1:

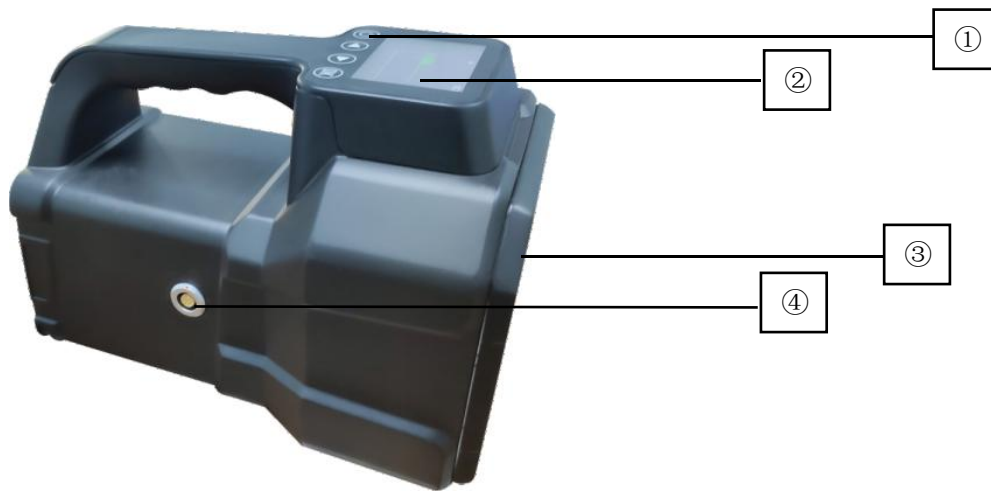

Fig. 1 Outline drawing of the detector mainframe

- ① Push button area: for operating the detector
- ② Screen: displays the sound waveform and system information
- ③ Antenna end: for sending and receiving detection signals. During detection, the antenna end should be aligned with the object under detecting
- ④ aviation socket: for connecting headphones, power adapter and backup power supply

4.2 Components

- ① Headphones: for outputting audio information
- ② Power adapter: for charging the detector
- ③ Electronic specimen: for testing the detection function of the detector
- ④ Mechanical specimens: for testing the detection function of the detector
- ⑤ Electronic Audio Detector mainframe
- ⑥ Cable: for connection of the mainframe to the power adapter
- ⑦ Transit case: for the storage and transport of all components

4.3 Dimensions

equipment dimensions are shown in Table 2:

Table 2 Dimensions of the mainframe

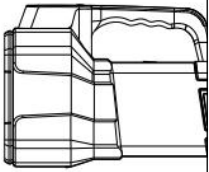
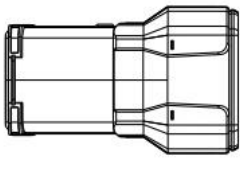
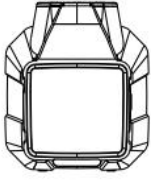
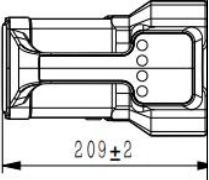
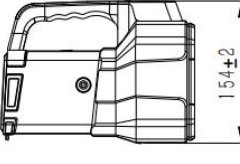
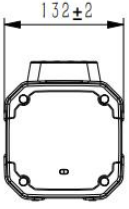
Outline structure diagram			
Dimensions			

4.4 How it works

The Electronic Audio Detector is an RF system based on carrier modulation technology. The principle of the electronic listener is: the transmitter transmits the fundamental wave signal, if there are mechanical timing devices or electronic timing devices in the detection area, the pointer of these devices will produce different degrees of vibration in the process of displacement, the receiver of the electronic listener will receive the fundamental wave and the vibration frequency signal of the measured object surface, and the received mixed signal will be filtered and amplified to restore the original vibration sound signal.

5 Installation and Commissioning

Upon receipt of the equipment, check the transit case for scratches or damage, open the transit case, take out the packing list, and check the detector and its accessories against the packing list.

The equipment is movable and does not need to be fixed, so it can be transported to the place where it needs to be used, works out of the box.

When you first receive the equipment, please read the manual carefully and follow the manual requirements or training requirements.

6 How to Use

6.1 Buttons and menus

6.1.1 Buttons

The buttons are shown in Figure 2.

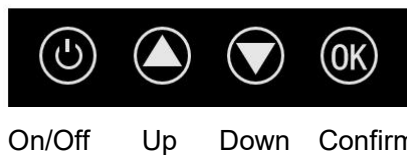

- ① On/Off button.
 - Press and hold for 3 seconds to turn on/off the equipment
 - Press return to the previous menu or the home screen
- ② Up button
 - In the home screen: press the up button to quickly adjust the waveform scan rate (cyclic adjustment)
 - In the system main menu: press the up button to move the cursor up
- ③ Down button
 - In the home screen: press the down button to adjust the volume quickly (cyclic adjustment)
 - In the system main menu: press the down button to move the cursor down
- ④ Confirmation button
 - In the home screen: press the confirm button to enter the main menu screen

- In the system main menu: confirm the selection displayed in the current screen/exit the current sub-menu to the main menu screen

6.1.2 Menus

The menu screens are shown in Figure 3.

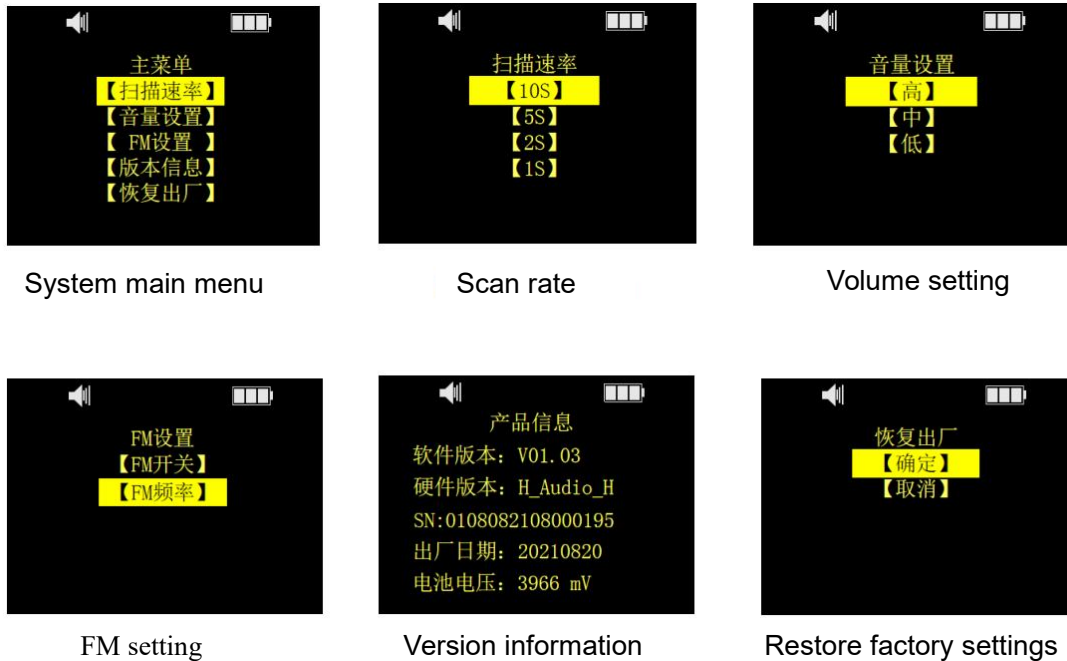

Fig. 3 Menu screens

- ① Press the confirm button to enter the system main menu screen
- ② Scan rate: Select the waveform scanning rate, save the settings, the waveform scanning rate on the home screen will be updated and will be the default setting for the next startup
- ③ Volume setting: Select the volume, save the settings, the volume on the home screen will be updated and will be the default setting for the next startup
- ④ FM setting: select On/Off FM and FM frequency
- ⑤ Version information: displays equipment version information
- ⑥ Restore factory settings: restore the settings to its default

6.2 Boot up the detector

Take the detector's mainframe out of the transit case, connect the headphones, and then press and hold the " on/off button" for three seconds to turn on the equipment, and then it will enter the working state.

6.3 Functional check

① After take out the mainframe and headphones from the transit case, connect the air plug of the headphones to the airline socket

② Press and hold the on/off button for 3 seconds to turn on the system, while the screen should display system information such as sound waveform and remaining power.

③ Press the up button and the scan rate displayed on the screen appears to change

④ Press the down button and the sound symbol  displayed on the screen should appear to change

⑤ Press the confirmation button and the system main menu screen appears

⑥ Take out the mechanical specimen, twist the specimen about 5 turns to make it in ticking, place it at the front of the equipment about 30cm, and a clattering sound should come out from the headphones

⑦ Take out the electronic specimen, press the switch button on the front of the specimen so that its green backlight is on for a long time, place it at the front of the equipment about 30cm, and an intermittent pulse sound should come out from the headphones

6.4 How to detect

- ① The equipment is connected to the headphones.
- ② Aim the antenna end at the object being tested, and during the detection process, the detector should scan slowly around the target at a uniform speed, and the equipment generating electromagnetic interference should be turned off as far as possible in the detection site.
- ③ When the detector detects a target, it transmits a signal to the headphones, and if the cover is complex or extensive, the exact location of the detected target can be determined using the intersecting detection method. The type of device detected can also be determined based on the characteristics of the signal sound heard from the headphones.

Various sound signal characteristics:

- Mechanical timer (mechanical watch or mechanical clock): the sound is generally similar to a mechanical gears
- Electronic clock (electronic hand clock): the sound is generally similar to a high speed low frequency pulse sound
- LCD electronic meter (electronic digital clock): the sound is generally similar to the sound of industrial frequency current

(The above experience is for reference only. Determine the detection result based on the actual situation)

6.5 Turn off the detector

Press and hold the on/off button for 3 seconds to turn off the detector.

6.6 Charging

Charging with the power adapter: Insert the circular connector into the aviation socket of the mainframe, and connect the USB port to the power adapter, as shown in the pictures in Figure 4 and Figure 5.



Fig. 4 Charging cable



Fig. 5 Power adapter charging

warning

When inserting the circular connector into the mainframe, align the red point of the connector with the red point of the socket. Otherwise, the socket may be damaged.

7 Maintenance

7.1 Maintenance of service life

In order to prolong the service life of the equipment, care should be taken in its daily use to.

note

- Attention to prevent dust、 moisture、 high temperature
- When the equipment is not in use, it should be placed indoors in a place without direct sunlight.
- When using, pay attention to the cable connection firmly and avoid exerting too much tension on the cable.
- Avoid strong impacts and knocks during use.

7.2 Daily maintenance

note

The equipment battery is a lithium ion low temperature battery, to maintain lithium ion activity and battery performance, the equipment should be fully charged and discharged every two months.

8 Troubleshooting

The general failure analysis and troubleshooting options for this equipment are shown in Table 3.

Table 3 Equipment Troubleshooting

Failure Description	Failure Analysis	Solutions
Equipment won't turn on	Out of power	1、 Connect the charging device to charge the equipment
No sound in headphones	Headphones sound is adjusted too low	1、 Confirm that the headphones connection cable is all properly connected 2、 Adjust the output volume level through the system menu

If the above general faults cannot be resolved by the solutions given, please contact the manufacturer.

9 Precautions

Danger

The equipment has a built-in lithium battery. To ensure safety, do not place the equipment or the backup battery in fire or water.

10 Transport, storage

10.1 Transport

① Attention to prevent dust 、 moisture 、 high temperature when transporting.

② All components must be transported in transit case to avoid bumps and drops.

10.2 Storage

① When loading and unloading, be gentle.

② Storage environment: The storage environment should be waterproof, moisture-proof, and snowproof. Do not store in the open air.

③ The storage environment should be away from high temperature and high heat.

④ After use, the protective cover should be installed on the multi-functional aviation socket to reduce the chance of foreign object contact and extend the service life of the socket.

⑤ The storage temperature of the equipment is -40°C to 70°C and 95% free of condensation.

11 Packing list

The list of packing is shown in table 4

Table 4 Equipment packing list

No.	Items	Quantities
1	Electronic audio detector mainframe (with display, internal battery)	1
2	Power adapter	1
3	Headphones	1
4	Electronic specimen	1
5	Mechanical specimen	1
6	Cable	2
7	User manual	1
8	Certificate of conformity	1
9	Packing list	1
10	Warranty card	1
11	Transit case	1