



Non-linear Junction Detector

ST-402 "CAYMAN"



Operating Manual

1. Description.....	1
1.1. Purpose.....	1
1.2. The Kit.....	1
1.3. Technical Specifications.....	2
1.4. Principles of Operation.....	2
1.5. Operation Modes.....	3
1.6. Structure.....	3
1.6.1. Antenna Module.....	4
1.6.2. Main Unit.....	5
1.6.3. Telescopic Arm.....	5
1.6.4. Control Buttons.....	6
2. Using the ST-402 Cayman.....	6
2.1. Preparation.....	6
2.2. ADAPTATION Mode.....	7
2.3. Functional Check with Imitators	8
2.4. SEARCH Mode.....	8
2.5. AUDIO Mode.....	10
3. Power Supply.....	12
4. Operating Restrictions.....	12
5. Storage and Transportation.....	13
6. Warranty.....	13

1. DESCRIPTION

1.1. PURPOSE

NLJD ST-402 CAYMAN is designed to detect electronic devices containing semiconductor elements.

NLJD ST-402 CAYMAN allows detecting, both on and off electronic devices and determine the place of their installation. The operator can distinguish responses from semiconductors from other responses, such as corrosion, metal-oxide-metal (MOM) structures, metal.

1.2. THE KIT

NLJD ST-402 CAYMAN is delivered in shockproof case.

The Kit contents:

Item	Quantity	# in Fig. 1
NLJD ST-402 CAYMAN	1	2
Accumulator (type 18650)	4	3
Charger Power Adapter	1	4
Charger	1	5*
Headphones	1	6*
Semiconductor Imitator (marked red)	1	1
MOM-Structure Imitator (marked blue)	1	1
Operating Manual (with passport)	1	Not shown in Fig.1
Case	1	Not shown in Fig.1

*The charger and headphones are located under the NLJD.

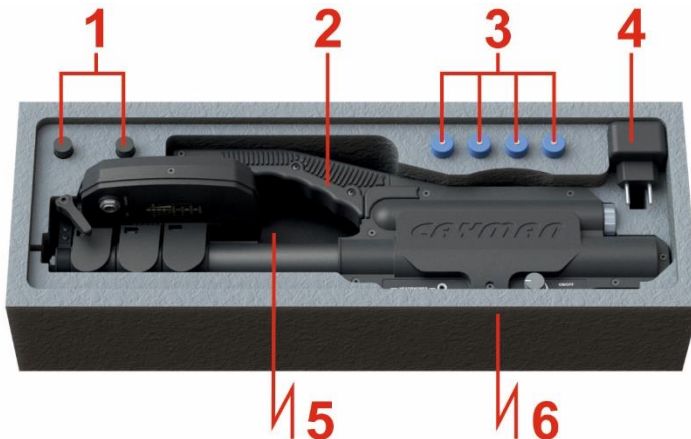

Fig. 1

1.3. TECHNICAL SPECIFICATIONS

Radiated frequency range	2–3GHz
Maximum peak radiated power	< 2W
Antenna polarization	Elliptic
Operation modes	SEARCH, AUDIO, ADAPTATION
Receiver sensitivity adjustment range in SEARCH mode	40dB (5 steps in 8dB steps)
Received signal level indication	
– visual	Three 16-segment LED scales
– acoustic	Internal speaker and headphones
Power supply	two 3.7V rechargeable Li-ion batteries (18650)
Continuous operation time from fully charged batteries	3-4 hours, depending on the operation mode
Batteries charging time	< 3 hours
Operating conditions	
– temperature range	+5...+40°C
– relative air humidity	up to 85% (at 25°C)
Weight (with batteries)	1,75kg
Dimensions (length×width×height)	
– when folded	510 x 145 x 130mm
– with telescopic arm pulled out completely	1500 x 250 x 130mm
Kit weight in shockproof case	5,5kg

1.4. PRINCIPLES OF OPERATION

The ability of a NLJD to detect objects containing electronic components is based on the following. Electronic devices consist of printed circuit boards with conductors (antennas) to which semiconductor elements are connected: diodes, transistors, microcircuits, representing a set of nonlinear converters for the probing signal of the NLJD.

As a result of irradiation, variable EMF is induced on these antennas. Elements with a nonlinear current-voltage characteristic of the probe signal are converted into high-frequency signals of multiple frequencies (harmonics), re-emitted into space. The re-emitted signal is fed to the input of the NLJD receiver. By the presence in the spectrum of the received signal of the higher harmonics of the eigenfrequencies of the transmitter, the fact of the presence of an electronic device in the sensing zone is established, regardless of whether it is turned on or off.

“False” signals for a NLJD can be reflections from touching metal surfaces. When such layers come into contact, a nonlinear element arises. This structure is known as a metal-oxide-metal (MOM). The MOM structure transforms the spectrum of the probing signal into a frequency spectrum that differs from the spectrum of the signal reflected from a semiconductor.

An important advantage of the ST-402 is its ability to distinguish with a high probability the responses of real semiconductor elements from “false” responses from MOM structures, as well as confident detection of search objects located behind partially shielding obstacles.

This effect is achieved due to the simultaneous emission of several frequencies in the 2–3GHz range and the analysis of the combinational components in the spectrum of the reflected signal.

1.5. OPERATION MODES

ST-402 CAYMAN has the following modes of operation:

- SEARCH mode - main operation mode
- AUDIO mode - auxiliary operation mode
- ADAPTATION mode - service mode

The SEARCH mode (main mode) is designed to detect the responses of nonlinear elements (the ratio of the levels of reflected signals is analyzed).

The AUDIO mode allows you to demodulate the target response and listen to it using the built-in speaker or headphones. It is advisable to use this mode after detecting a target response in the SEARCH mode.

ADAPTATION mode is a service mode. It is designed to tune the NLJD to optimal parameters and ensure the most efficient search in a specific electromagnetic environment.

It is necessary to use ADAPTATION mode every time after turning on the NLJD and periodically during the search process. When adapting, the antenna should be directed away from electronics and large metal objects.

1.6. STRUCTURE

ST-402 CAYMAN consists of the main unit and antenna module. They are connected with a telescopic arm. The main constituents are shown in Fig. 2.

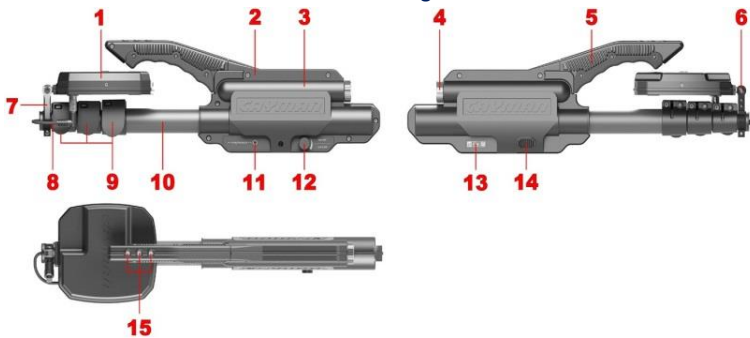

Fig. 2

- | | |
|--------------------------------------------|-----------------------------------|
| 1 - antenna module | 10 - telescopic arm |
| 2 - main unit | 11 - headphone socket |
| 3 - battery compartment | 12 - power on/off and volume knob |
| 4 - battery compartment cap | 13 - information shield |
| 5 - handle | 14 - internal speaker |
| 6 - antenna module bracket | 15 - control buttons |
| 7 - lever handle of the clamp | |
| 8 - power/control cable with plug | |
| 9 - eccentric clamps of the telescopic arm | |

1.6.1. ANTENNA MODULE

The antenna module comprises a receiver- transmitter unit, a control-display unit, and an aerial, all of which are assembled on a single platform and incorporated in a single body. The antenna is mounted at the end of a telescopic arm by way of a hinge joint that allows adjusting the incline within the vertical plane along the rod's axis, as shown in Fig. 3. To change the incline, unlock the clamp by turning its handle counter-clockwise, as shown in Fig. 3, then adjust and lock by turning the clamp handle in the clockwise direction.



Fig. 3

It is forbidden to change the position of the antenna module when the clamp is fixed. This can lead to breakage of the swivel joint!

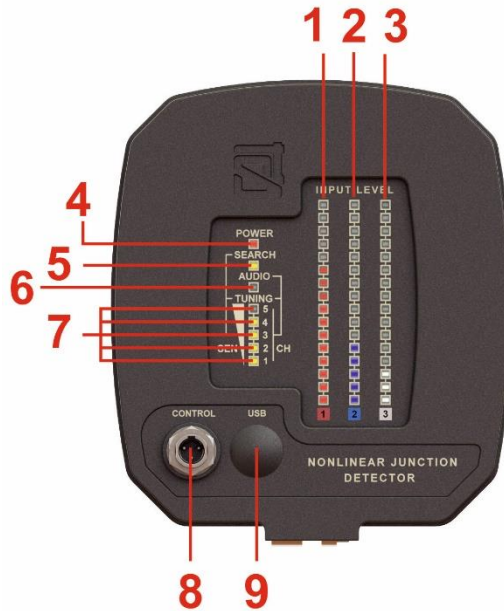

Fig. 4

On the side of the antenna module facing the operator (Fig. 4), there is an indicator panel, a socket for connecting a control / power cable and a USB connector for connecting a PC
The numbers in Fig. 4:

# in Fig. 4	Description	Colour	Designation on panel
1	16 segment LCD indicator of the level of "dangerous" responses	red	1
2	16-segment LCD indicator of MOM-type response level	blue	2

# in Fig. 4	Description	Colour	Designation on panel
3	16-segment LCD indicator of reflective surfaces level	white	3
4	Power-on led indicator	red	POWER
5	SEARCH mode indicator	yellow	SEARCH
6	AUDIO mode indicator	yellow	AUDIO
7	Tuning indicator *	yellow	TUNING
8	Socket for power-and-control cable		CONTROL
9	USB port (not used)		USB

* The TUNING indicator has two functions:

- in the SEARCH mode, it shows the selected sensitivity of the receiver (SEN)
- in the AUDIO mode, it shows the selected frequency combination (CH 1..5)

The directions of the maxima of the receiving and transmitting antennas are shown in Fig. 5.

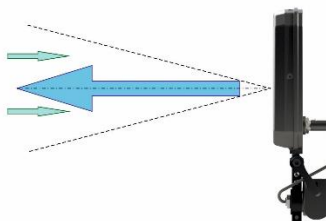

Fig. 5

1.6.2. MAIN UNIT

The main unit is assembled in a sturdy plastic case (2, Fig. 2). In the upper part of the main unit body there is a handle (5, Fig. 2) with three control buttons (15, Fig. 2). Inside the main unit case there is a battery compartment (3, Fig. 2) for two batteries (type 18650). The battery compartment is closed with a metal cover (4, Fig. 2). On the left side of the case there is a headphone jack (11, Fig. 2) and a power switch / volume control (12, Fig. 2). On the right side of the case there is a shield with information about the device name, serial number and manufacturer (13, Fig. 2) and the internal speaker (14, Fig. 2). The electronic control unit of the device is located inside the housing.

1.6.3. TELESCOPIC ARM

The four-section telescopic arm is designed to bring the antenna module closer to the tested object. With the help of eccentric clamps (9, Fig. 2), you can set the required rod length. The telescopic bar is rigidly attached to the supporting structure inside the main unit. The front part of the telescopic arm is equipped with a bracket for attaching the antenna module (6, Fig. 2).

The antenna module is fixed in the required position using a lever handle (7, Fig. 2).

Inside the telescopic arm there is a twisted cable connecting the antenna module with the power and control units located in the main unit. Figure 6 shows the ST-402 with the telescopic arm folded (A) and maximally extended (B).

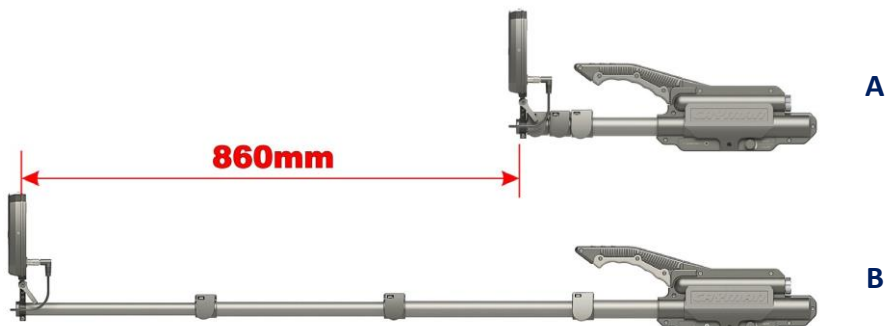

Fig. 6

1.6.4. CONTROL BUTTONS

There are three control buttons in the front of the handle (Fig. 7).

The button for setting the operating modes (2, Fig. 7 is marked with the symbol)

A short press of this button turns on one of the two modes SEARCH or AUDIO. Holding the button for a few seconds switches the device to the ADAPTATION mode.

The buttons ∇ \triangle (1 and 3, Fig. 7) are intended for setting the ST-402 parameters.

Depending on which of the two modes the device is in, these buttons allow:

- in SEARCH mode - increase and decrease the receiver sensitivity;
- in AUDIO mode - set the required frequency combination.



Fig. 7

2. USING THE ST-402 CAYMAN

2.1. PREPARATION

1. Get the ST-402 and batteries from the case.
2. Check the main unit, antenna module, cable and connector for mechanical damage.
3. Check the batteries for mechanical damage and corrosion of the contacts.

In the presence of these problems, the operation of the ST-402 is prohibited!

4. Install batteries in the ST-402 (Fig. 8):

- unscrew the battery compartment cover,
- observing the polarity, insert two batteries into the battery compartment,
- screw on the battery compartment cover.



Fig. 8



Fig. 9

5. Make sure that the power switch knob (12, Fig. 2) is in the extreme left position (off).
6. Connect the power/control cable connector (8, Fig. 2) to the socket of the antenna module (8, Fig. 4).

Attention! The cable connector is equipped with a lock. To disconnect the connector, press the button on its side surface (Fig. 9).

7. Switch on the ST-402 by turning the power switch knob clockwise. Light indication will appear on the antenna module in accordance with Table 1.

Table 1

Legend	Colour	Light indication	Interpretation
POWER	red	continuous	Standard power supply
		blinking	The batteries are discharged
TUNING SEN	yellow	continuous	Indicator of the receiver sensitivity set value. After turning on the ST-402, the maximum value is automatically set. In this case, all 5 segments of the indicator light up
SEARCH	yellow	continuous	Operating mode indicator. When the ST-402 is turned on, the SEARCH mode is automatically set

After turning on the ST-402, periodic spontaneous illumination of one or more segments of the signal level indicators is possible (1-3, Fig.4). This indicates the need to adapt the ST-402 to the current electromagnetic environment.

2.2. ADAPTATION MODE

To activate the ADAPTATION mode, press the button (2, Fig. 7) and hold it for 3-4 seconds. In this case, the antenna should be directed away from large metal objects and objects containing nonlinear elements. It is best to point the antenna towards the floor or ceiling.

The adaptation process takes 10-15 seconds. In this case, all indicators on the panel of the antenna module light up, except for the TUNING indicator.

In the TUNING indicator, the segments light up in sequence. Thus, during the adaptation process, the operator has the ability to monitor the health of all segments of the indicators on the antenna module panel. At the end of the adaptation, the state of the indicators of the antenna module corresponds to Table 1.

2.3. FUNCTIONAL CHECK WITH IMITATORS

After adaptation, it is necessary to check the functionality of the ST-402 CAYMAN using a semiconductor imitator and a MOM-structure imitator (1, Fig. 1).

To do this, you need to select a place in the room where there are no responses from nonlinear elements and reflective surfaces and set an imitator with red marking.

By successive pressing of the button  (3, Fig. 7) set the receiver sensitivity in such a way that 3 segments are lit on the TUNING indicator, which corresponds to the medium value of the receiver sensitivity.

Direct the antenna at the imitator. Move the antenna towards and away from the imitator to determine the distance at which all 16 segments light up on scale 1 (red) of the INPUT LEVEL indicator. For a serviceable and correctly adapted ST-402, this distance should be at least 0.8 m. Then repeat this procedure using the imitator with blue markings. It is necessary to determine the distance from the antenna to the imitator when all 16 segments of the scale 2 (blue) of the INPUT LEVEL indicator light up. For a serviceable and correctly adapted ST-402, this distance should be at least 0.3 m. If the distances correspond to the specified standards, this means that the ST-402 CAYMAN is in good working order, correctly adapted and ready for work.

2.4. SEARCH MODE

After completing the procedures specified in 2.1-2.3, you can start working with the ST-402. After turning on the ST-402 automatically switches to the SEARCH mode and the maximum value of the receiver sensitivity is set (all five segments of the TUNING indicator lit).

The operator has the ability to change the receiver sensitivity, thereby increasing or decreasing the target detection range.

The range of variation of the receiver sensitivity is 40 dB (five steps of 8 dB). Each step of sensitivity change (8 dB) corresponds to one segment of the TUNING indicator. Glowing of five segments of the TUNING indicator means that the sensitivity is set to 40dB and the maximum target detection range is provided.

If no segment of the TUNING indicator is lit, it means that the receiver sensitivity is 0dB and the target detection range is the smallest.

The receiver sensitivity can be changed by one step (8 dB) by pressing the buttons  or  once (1 and 3 Fig. 7).

Scale 1 of the INPUT LEVEL indicator (16 red segments) displays the level of response reflected by the semiconductor. The indication on this scale is accompanied by an audio signal of alternating tone.

Scale 2 of the INPUT LEVEL indicator (16 blue segments) displays the level of the response reflected by the MOM structures.

Scale 3 of the INPUT LEVEL indicator (16 white segments) displays the level of response reflected by various reflective surfaces (most likely metal).

The higher the level of response from the probed object, the more segments light up in the corresponding scale of the INPUT LEVEL indicator.

RECOMMENDATIONS

The objects of location in a room can be enclosing structures (walls, ceilings, floors), interior elements, various objects that obviously do not contain semiconductors.

Items containing semiconductors (office and household appliances, communications equipment, etc.) are checked in other ways. When locating enclosing structures, it is important to correctly set the receiver sensitivity. If the sensitivity is set too high, there is a high probability of detecting objects behind the enclosing structures. This is a problem if access to adjacent rooms is not possible. If you set the sensitivity too low, it is possible to miss a target located in the target structure and giving a weak response.

While scanning walls and other large vertical structures, it is recommendable to move the antenna from top to bottom in a serpentine fashion, as is shown in Fig. 10.

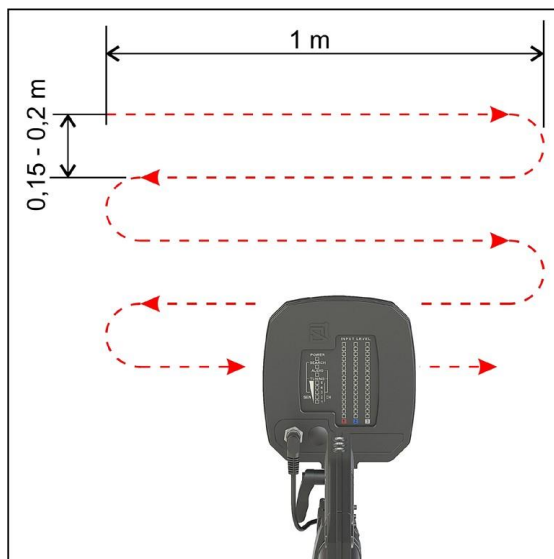

Fig. 10

The distance from the antenna to the sounded surface should be within 5 to 15 cm.

If a strong response is detected (all segments of the indicator scale are illuminated), it is recommended to reduce the sensitivity.

The main task of NLJD is to detect eavesdropping devices. It is assumed that the main unmasking feature will be the presence of semiconductor elements (electronic components) and MOM structures in their composition.

Based on this, the operator should pay special attention to those objects where responses were received on the red scale (or red and blue scales at the same time) of the INPUT LEVEL indicator. The nature of each such response must be determined and the source identified. When a powerful (off-scale) response is detected on one of the indicator scales, a response on another scale can also be observed. In such cases, it is necessary to reduce the sensitivity to obtain an indication of only one of the scales. Typically, a response with a high level is true, and a response with a lower level is false.

Small objects are checked in an area where there are no responses on all three scales of the INPUT LEVEL indicator.

It is desirable that large metal structures are not located near the selected place.

2.5. AUDIO MODE

The AUDIO mode is intended for analyzing responses by listening to demodulated signals. The operator receives information to correctly classify the detected response.

To switch from SEARCH mode to AUDIO mode, press button.

The SEARCH indicator on the antenna module panel goes out (5, Fig.4) and the AUDIO indicator lights up (6, Fig. 4).

When the AUDIO mode is turned on, an indication is set on the antenna module panel in accordance with Table 2.

Table 2

Legend	Colour	Light indication	Interpretation
POWER	red	continuous	Standard power supply
		blinking	The batterys are discharged
TUNING	yellow	continuous	The 5-segment indicator that displays set frequency combination
AUDIO	yellow	continuous	AUDIO mode is on
INPUT LEVEL (scale#3)	white	varying numbers of lit LEDs	16-segment input level meter. In AUDIO mode, the indicator does not show the level of the response from the reflective surface, but the level of the demodulated signal

When AUDIO mode is turned on, none of the five segments of the TUNING indicator light up.

The ST-402 provides the ability to analyze the demodulated signal when the transmitter emits six different frequency combinations.

Each of these combinations is designed to explore different types of nonlinear objects. The combination number is shown on the TUNING indicator.





When the AUDIO mode is turned on, the frequency combination is set to # 0. It is focused on the study of objects containing semiconductors. This combination gives good results in identifying working radio transmitting and sound recording devices.

Frequency combination # 1 is focused for analysis of signals from MOM structures.

The other four frequency combinations are optional. It is recommended to use them when analyzing responses received in search modes on the "red" scale of the INPUT LEVEL indicator in cases where it was not possible to obtain a positive response at a "zero" frequency combination.

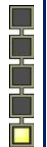
Table 3 shows the correspondence of the indication of frequency combinations to the responses received in the SEARCH mode.

Table 3

	Indication on TUNING bar					
						
Frequency combination #	0	1	2	3	4	5
Scale # of the INPUT LEVEL indicator in SEARCH mode	1	2	1	1	1	1

Use buttons ∇ and \triangle to change frequency combinations (1 and 3, Fig.7).

Table 4 shows typical results of acoustic analysis of objects with “nonlinear” properties.

Table 4

Type of probed target	Optimum frequency combination	Reaction to mechanical impact and test sound	Reaction in the absence of mechanical impact and control sound
MOM-structure	1	Crackle, creak	none
Active electronic devices (unencoded transmission channel)	0 (2-5)	Audible response to tapping or test sound	Acoustic background of the room
Active electronic devices (encoded transmission channel)	0 (2-5)	Specific signals associated to the operation of the device, but not associated to acoustic signals in the room	Specific signals associated with the operation of the device, but not associated with acoustic signals in the room
Inactive electronic devices	0 (2-5)	none	none
Active electro-mechanic or mechanic devices	0-5	Crackle, creak	Specific signals associated with the operation of the device, but not associated with acoustic signals in the room

It is recommended to listen to the demodulated signals through headphones. Volume control is carried out using a volume knob (12, Fig. 2).

RECOMMENDATIONS

Any response received on the “red” scale (or simultaneously on the “red” and “blue” scales) must be analyzed in the AUDIO mode using a source of the control sound. Any device that generates an acoustic signal (radio receiver, MP3 player, etc.) can be used as the source of the control sound. If the response is received on a “blue” scale, it is advisable to conduct an acoustic analysis on a combination of frequencies # 1 with a mechanical effect on the sounding object.

When probing an object, it is recommended to smoothly change the distance from the antenna to the object (in the range of 5-100 cm).

Push  to switch from the AUDIO mode to SEARCH.

3. POWER SUPPLY

ST-402 is powered by two Li-ion batteries (type 18650). The standard set contains 4 batteries. The operating time of the ST-402 from fully charged batteries is 3-4 hours (depending on the operating mode). The greatest power consumption occurs in the AUDIO mode. The batteries are housed in the battery compartment of the main unit. The process of installing batteries is described in 2.1.

ST-402 has a system for monitoring the battery charge level. A permanently lit POWER indicator (4, Fig. 4) located on the antenna module panel indicates that the batteries are sufficiently charged. When the charge level changes below the permissible level, the POWER indicator starts blinking. The blinking POWER indicator is accompanied by a beep. When the charge level drops below the critical one, ST-402 automatically turns off.

The batteries are charged using the supplied charger. The charging time for fully discharged batteries is 3 hours. Due to the fact that batteries that do not have a “memory effect” are used in ST-402, an incomplete charge of the batteries is allowed. In this case, the operating time will be less than the one specified above.

The following is not allowed:

- long-term storage of completely discharged batteries
- long-term storage of batteries at low air temperatures
- short-circuiting battery contacts
- subjecting batteries to strong shock
- transportation of the ST-402 CAYMAN with an installed battery.

4. OPERATING RESTRICTIONS

When using ST-402, you should follow the safety rules adopted when working with devices that have open microwave signal emitters:

- **do not allow people to stay for a long time in the direction of radiation (the main lobe of the antenna system directional diagram) at a distance of less than 1 meter.**
- **do not direct the antenna towards human eyes from a distance closer than 1 meter.**

Before using the ST-402, it must be in a room with an operating temperature for 2 hours.

5. STORAGE AND TRANSPORTATION

NLJD ST-402 must be stored in a heated room.

Storage conditions:

- ambient temperature from 0 to + 50° C;
- relative air humidity 80% at 30° C;
- atmospheric pressure from 630 to 820 mmHg;
- absence of vapors of acids, alkalis and aggressive impurities in the room.

Transportation must be carried out under the condition of protection from the effects of precipitation. Drops and sharp blows leading to mechanical damage are not allowed.

6. WARRANTY

Warranty period - 12 months from the date of sale. Warranty repair is carried out subject to the rules of operation, transportation and storage, in the absence of mechanical damage.